





Arch. Franco Driusso

THINK SMART, WORK EASY.

Vivere l'ambiente di lavoro in modo flessibile e intelligente, in un habitat personalizzato.

E' l'idea progettuale che ha ispirato YQ, l'innovativo sistema d'arredo che risponde a molteplici esigenze operative e funzionali.

Un concept che si rivolge trasversalmente a tutti i livelli dell'ambiente di lavoro: workstation, open space, zona meeting, executive e reception.

To live the working environment in a flexible and smart way in a customised habitat.

This is the design idea which inspired YQ, the innovative furniture system which corresponds to several functional and operational needs.

A concept closely addressed to all levels of the working environment: workstation, open space, meeting area, executive and reception.

Vivre le milieu de travail de manière flexible et intelligente, dans un habitat personnalisé.

C'est l'idée conceptuelle qui a inspiré YQ, l'innovatif système d'ameublement qui répond à de nombreuses exigences opérationnelles et fonctionnelles.

Un concept qui s'adresse transversalement à tous les niveaux du milieu de travail : workstation, open space, zone meeting, direction et réception.

In einem individuellen Habitat das Ambiente auf flexible und intelligente Art erleben.

Dies ist der Grundgedanke, der die Planung YQS inspiriert hat, das innovative Einrichtungssystem, das auf zahlreiche betriebliche und funktionelle Anforderungen eine Antwort gibt.

Ein Konzept, das sich quer durch alle Niveaus des Arbeitsumfeldes zieht: Workstation, Open Space, Meeting-Bereich, Executive und Rezeption.

Vivir el espacio de trabajo de manera flexible e inteligente, en un hábitat personalizado.

Esta es la idea de proyecto que ha servido de inspiración para YQ, el innovador sistema de mobiliario que se ajusta a múltiples necesidades operativas y funcionales.

Un concepto orientado transversalmente a todos los niveles del espacio de trabajo: estaciones de trabajo, open space, zona de reuniones, dirección y recepción.

Создание гибкой рабочей обстановки с разумным подходом, отвечающей индивидуальным требованиям современного офисного интерьера.

Такова идея проекта, которая была в основе коллекции YQ – новаторской системы дизайна интерьеров, отвечающей многочисленным оперативным и функциональным требованиям.

Концепция, которая охватывает все уровни рабочей обстановки: рабочее место, открытое пространство, зона встреч и собраний, административная зона и ресепшн.





MULTISYSTEM

Le differenti tipologie della struttura in metallo ed i fianchi laterali, descrivono il carattere versatile e poliedrico di YO.

Un sistema dinamico che si adatta facilmente ad ambienti in continua evoluzione.

Die unterschiedlichen Ausführungen des Metallaufbaus und der Außenseiten beschreiben den vielseitigen Charakter YOS.

Ein dynamisches System, das sich leicht jedem in ständiger Entwicklung befindlichem Umfeld anpasst.

The different metal typologies and side panels, describe the versatile and polyhedral character of YO.

A dynamic system which easily adapts to spaces in continuous evolution.

Los diferentes tipos de la estructura de metal y los costados laterales describen el carácter versátil y polidrico de YO.

Un sistema dinámico que se adapta fácilmente a espacios en continua evolución.

Les différentes typologies de la structure en métal et les parties latérales décrivent le caractère versatile et polyédrique de YO.

Un système dynamique qui s'adapte facilement à des milieux en évolution continue.

Различные виды металлических конструкций и боковин демонстрируют гибкий и многогранный характер YO.

Динамичная система, которая легко адаптируется к постоянно изменяющейся обстановке.

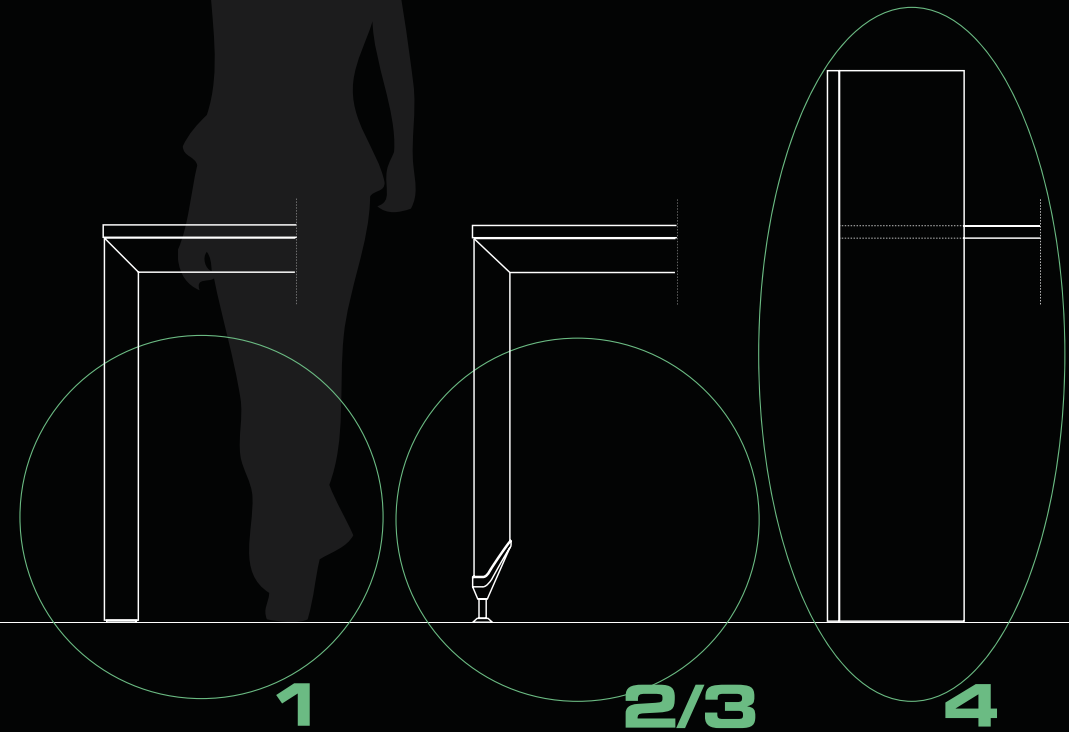

1

2/3

4





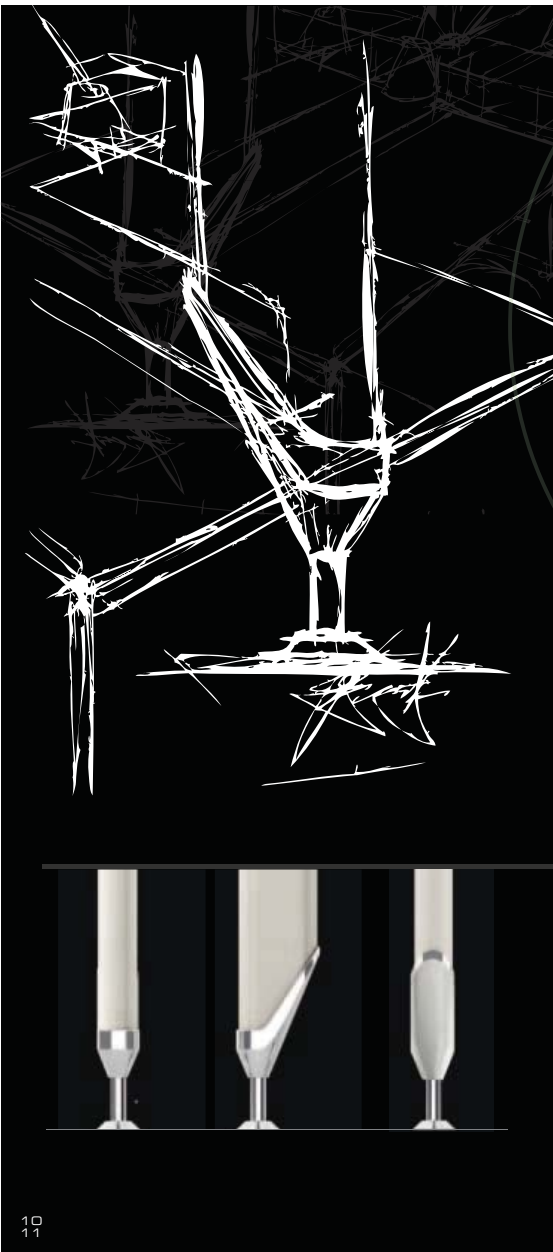

740

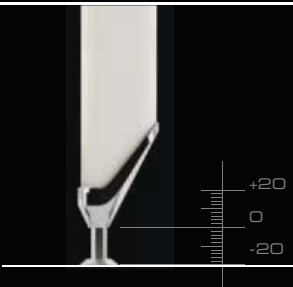

720

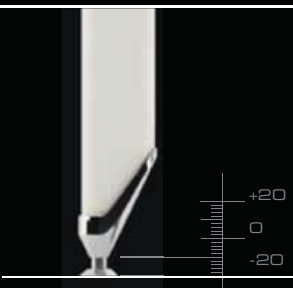

760



L'elegante puntale in pressofusione di alluminio, dalla forma fluida e dinamica, consente la regolazione in altezza delle scrivanie, favorendo la flessibilità operativa.

The stylish cast aluminium foot, with fluid and dynamic shape, allows the height adjustment of the desks, favouring the operational flexibility.

L'élégant embout en aluminium moulé sous pression, à la forme fluide et dynamique, permet le réglage en hauteur des bureaux, en favorisant la flexibilité opérationnelle.

Der elegante Pfeiler aus Aluminiumdruckguss ermöglicht mit seiner fließenden und dynamischen Form die Höheneinstellung der Schreibtische und unterstützt die Arbeitsflexibilität.

El elegante nivelador de aluminio fundido a presión, con su forma fluida y dinámica, permite regular la altura de los escritorios, favoreciendo la flexibilidad operativa.

Элегантный наконечник, отливаемый из алюминия под давлением, текучей и динамичной формы, позволяет регулировать высоту письменных столов, способствуя оперативной гибкости.





Il rigore estetico delle forme e la leggerezza dei volumi favoriscono la fruibilità e la naturale interazione nell'ambiente di lavoro.

The aesthetic precision of the shapes and lightness of volumes promote the usability and natural interaction in the workplace.

La rigueur esthétique des formes et la légèreté des volumes favorisent l'usage et l'interaction naturelle dans le milieu de travail.

Die ästhetische Strenge der Formen und die Leichtigkeit der Rauminhalte fördern die Nutzbarkeit und das natürliche Zusammenwirken im Arbeitsbereich.

El rigor estético de las formas y la ligereza de los volúmenes facilitan el uso y la interacción natural en el espacio de trabajo.

Эстетическая строгость форм и легкость объемов расширяют возможности использования и способствуют естественному взаимодействию с рабочей средой.





chromaticSensing

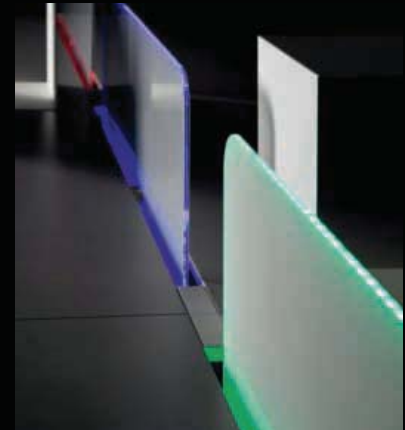



COLOUR ENERGY WELLNESS

Numerosi studi hanno dimostrato l'effetto benefico della luce e del colore sul nostro organismo.

Il colore è un'esperienza sensoriale percepita dai nostri sensi sottoforma di energia, che influenza le nostre emozioni e il nostro stato d'animo.

Gli schermi divisorii YO, con sistema opzionale di retroilluminazione a LED, consentono di ottenere equilibri cromatici di volta in volta differenti.

Numerous studies have demonstrated the beneficial effect of light and colour on our body.

The colour is a sensory experience perceived by our senses in the form of energy that affects our emotions and our moods.

The partition screens by YO, with optional rear LED lighting system, allow getting colour balance different from time to time.

De nombreuses recherches ont démontré l'effet bénéfique de la lumière et de la couleur sur notre organisme.

La couleur est une expérience sensorielle perçue par nos sens sous forme d'énergie, qui influence nos émotions et notre état d'âme.

Les cloisonnettes YO, avec système en option de rétroéclairage à LED, permettent d'obtenir des équilibres chromatiques chaque fois différents.

Zahlreiche Studien beweisen diese wohltuenden Wirkungen auf unseren Lebensgeist.

Die Erfahrung wie die Farben in Form von Energie durch unsere Sinne erfasst werden.

Sie beeinflussen alle unsere Empfindungen und Gemutszustände. Die Trennwände YO ermöglichen dies mit dem Optionellen erdachten rückseitigen LED-Beleuchtungssystem. Dies ermöglicht eine unterschiedliche chromatische Ausgewogenheit.

Numerosos estudios han demostrado el efecto beneficioso de la luz y del color en nuestro organismo.

El color es una experiencia sensorial percibida por nuestros sentidos en forma de energía, que influye en nuestras emociones y nuestros estados de ánimo.

Las paredes separadoras de YO, con sistema opcional de retroiluminación LED, permiten obtener equilibrios cromáticos siempre diferentes.

Многочисленные исследования продемонстрировали благоприятное воздействие света и цвета на организм человека.

Цвет является чувственным опытом, воспринимаемым нами в форме энергии, которая влияет на наши эмоции и состояние души.

Разделительные экраны YO с опциональной системой светодиодной подсветки позволяют добиться различного цветового баланса в каждом конкретном случае.



chromaticensing



Red

E' il simbolo della vitalità. Ha un effetto benefico trasmettendo sensazioni di calore ed energia.

It's the symbol of vitality. It has a beneficial effect by transmitting heat and energy sensations.

C'est le symbole de la vitalité. Il a un effet bénéfique en transmettant des sensations de chaleur et d'énergie.

Ist das Symbol der Lebenskraft. Überträgt die Sensation eines Wohligefühls von Wärme und Energie.

Es es el símbolo de la vitalidad. Tiene un efecto beneficioso, al transmitir sensaciones de calor y energía.

Это символ жизненной силы. Обладает благоприятным эффектом, придает ощущение тепла и энергии.

Orange

Trasmette una sensazione piacevole e riscaldante. Aiuta la mente ad aprirsi e stimola l'estroversione.

It transmits a pleasant and heating sensation. It helps the mind to get open and stimulates the extroversion.

Il transmet une sensation agréable et réchauffante. Il aide l'esprit à s'ouvrir et stimule l'extroversion.

Ein Wärmeausstrahlendes Gefühl. Regt Gemüt und Stimmung sowie Extraversion an.

Transmite una sensación agradable y cálida. Ayuda a la mente a abrirse y estimula la extroversión.

Придает приятные и теплые ощущения. Помогает открыться мышлению и стимулирует экстравертность.

Yellow

Esprime positività, serenità e luminosità. Favorisce le facoltà logiche e di ragionamento.

It expresses positivity, serenity and radiance. Encourages the faculties of reasoning and logic.

Il exprime la positivité, la sérénité et la luminosité. Il favorise les facultés logiques et de raisonnement.

Ausdrückt von Positivität, Heiterkeit und Lichteffekt. Fördert die Logischen Überlegungsfähigkeiten.

Expresa positividad, serenidad y luminosidad. Potencia las facultades lógicas y de razonamiento.

Выражает позитивность, спокойствие и яркость. Стимулирует логические способности и способствует мысленной активности.

Green

E' il colore per antonomasia della natura. Ha un'influenza rilassante, favorendo l'armonia e l'equilibrio.

It's the colour of nature for excellence. It has a relaxing influence and promotes harmony and balance.

C'est la couleur par antonomase de la nature. Il a une influence délassante et il favorise l'harmonie et l'équilibre.

Ist die Antonomasische Farbe der Natur. Überträgt und bewirkt einen Einfluss von harmonischer Ausgeglichenheit.

Es es el color de la naturaleza por antonomasia. Tiene un efecto relajante y propicia la armonía y el equilibrio.

Это цвет природы по определению. Влияет расслабляющим образом и способствует достижению гармонии и душевного равновесия.

Blue

E' infinito, come l'etere. Trasmette sensazioni di tranquillità, ampiezza e libertà.

It's infinite, like the sky. It transmits sensations of calm, spaciousness and freedom.

Il est infini, comme l'espace. Il transmet des sensations de tranquillité, d'ampleur et de liberté.

Überträgt die Unendlichkeit, ätherische Ruhe, Weite und Freiheit.

Es infinito, como el espacio. Transmite sensaciones de tranquilidad, amplitud y libertad.

Бесконечен как небо. Придает ощущение спокойствия и свободы.

Indigo

E' il colore dell'equilibrio e del pensiero logico. Comunica ordine, perfezione e tranquillità.

It's the colour of balance and of the logic thinking. It communicates order, perfection and serenity.

C'est la couleur de l'équilibre et de la pensée logique. Il communique ordre, perfection et tranquillité.

Ist die Farbe der Ausgewogenheit und des logischen Denkens. Überträgt Perfektion und Ruhe.

Es es el color del equilibrio y del pensamiento lógico. Comunica orden, perfección y tranquilidad.

Это цвет равновесия и логического мышления. Привносит порядок, совершенство и спокойствие.

Violet

Stimola le qualità intuitive e spirituali. Favorisce la concentrazione e l'ispirazione creativa.

Stimulates the intuitive and spiritual qualities. Promotes concentration and creative inspiration.

Il stimule les qualités intuitives et spirituelles. Il favorise la concentration et l'inspiration créative.

Ansporn für Intuition und deren Lebensgeist sowie für eine kreative Konzentrationsfähigkeit.

Estimula las cualidades intuitivas y espirituales. Favorece la concentración y la inspiración creativa.

Стимулирует интуитивные и духовные качества. Способствует концентрации и творческому вдохновению.







Finitura_melaminico Texture grigio
 Struttura_metallo grafite
 Struttura_cassettiere_melaminico
 antracite
 Maniglia_cassettiere_metallo
 cromato

Finish_Texture grey melamine
 Structure_graphite metal
 Chest of drawers structure_
 anthracite melamine
 Chest of drawers handles_
 chromed metal

Finition_mélatiné Texture tissu gris
 Structure_métal anthracite
 Structure_caissons_mélatiné
 anthracite
 Poignée_caissons_métal chromé

Oberfläche_melaminbeschichtet in
 Textildécor grau
 Metallgestell_Farbe graphit
 Schubkastenfächer_Korpus_
 melaminbeschichtet in anthrazit
 Schubkastenfächer_Griff_
 Metallic verchromt

Acabado_melamina Texture gris
 Estructura_metal grafita
 Estructura_cajoneras_melamina
 antracita
 Tiradores_cajoneras_metal cromado

Отделка_меламин Texture серый
 Структура_металл антрацит
 Структура_тумбочек_меламин антрацит
 Ручки тумбочек_металл хромированный





Finitura_melaminico Texture grigio/
 antracite, bianco
 Struttura_metallo bianco
 Screen_metacrilato antracite,
 cristallo
 Porta_dox_metallo bianco

Finish_melamine in Texture grey/
 anthracite, plain white
 Structure_white metal
 Screen_anthracite methacrylate,
 crystal
 Binder_holder_white metal

Finition_mélaniné Texture gris/antracite,
 blanc
 Structure_métal blanc
 Cloisonnette_méthacrylate
 anthracite, verre
 Range-classeurs_métal blanc

Oberfläche_melaminbeschichtet in
 Textildector grau/antrazit, weiß
 Metallgestell_Farbe weiß
 Screen_Methacrylat antrazit,
 Crystal
 Behälter für Aktenordner_Metall
 weiß

Acabado_melamina Textura gris/
 antracita, blanco
 Estructura_metal blanco
 Pared_metacrilato antracita, cristal
 Porta_archivadores_metal blanco

Отделка_меламин Texture серый/антрацит,
 белый
 Структура_металл белый
 Перегородка_метакрилат антрацит, стекло
 Подставка для папок_металл белый



chromaticensing

Finitura_melaminico bianco
 Struttura_metallo bianco
 Screen_cristallo
 Porta_documento_metallo bianco

Finish_white melamine
 Structure_white metal
 Screen_crystal
 Binder_holder_white metal

Finition_mélangé blanc
 Structure_métal blanc
 Cloisonnette_verre
 Range-classeurs_métal blanc

Oberfläche_melaminbeschichtet weiß
 Metallgestell_Farbe weiß
 Screen_Crystal
 Behälter für Aktenordner_Metall weiß

Acabado_melamina blanco
 Estructura_metal blanco
 Pared_cristal
 Porta_archivadores_metal blanco

Отделка_меламин белый
 Структура_металл белый
 Перегородка_стекло
 Подставка для папок_металл белый



Finitura_melaminico noce
Struttura_metallo bianco
Screen_metacrilato bianco

Oberfläche_melaminbeschichtet in
 Farbe_Nussbaum
 Metallgestell_Farbe weiß
 Screen_Methacrylat weiß

Finish_walnut melamina
Structure_white metal
Screen_white methacrylate

Acabado_melamina nogal
 Estructura_metal blanco
 Pared_metacrilato blanco

Finition_méliné noyer
Structure_métal blanc
Cloisonnette_méthacrylate blanc

Отделка_меламин орех
 Структура_металл белый
 Перегородка_метакрилат белый







Finitura_melaminico Texture grigio
 Struttura_metallo grafite
 Struttura_armadi_melaminico
 antracite

Oberfläche_melaminbeschichtet in
 Textildector grau
 Metallgestall Farbe graphit
 Schränke Korpus_
 melaminbeschichtet in anthrazit

Finish_Texture grey melamine
 Structure_graphite metal
 Storage units structure_anthracite
 melamine

Acabado_melamina Textura gris
 Estructura_metal grafita
 Estructura_armarios_melamina
 antracita

Finition_mélatiné Texture tissu gris
 Structure_métal anthracite
 Structure_armoires_mélatiné
 anthracite

Отделка_меламин Texture серый
 Структура_металл антрацит
 Структура_шкафов_меламин антрацит







Finitura_melaminico noce
Struttura_metallo bianco
Elementi divisorii_melaminico bianco
Porta_cox_metallo bianco

Finish_walnut_melamine
Structure_white metal
Dividing units_white melamine
Binder holder_white metal

Finition_mélaniné noyer
Structure_métal blanc
Panneaux-pieds_mélaniné blanc
Range-classeurs_métal blanc

Oberfläche_melaminbeschichtet in
Farbe Nussbaum
Metallgestell_Farbe weiß
Trennwände_melaminbeschichtet in
Farbe weiß
Behälter für Aktenordner_Metall
weiß

Acabado_melamina nogal
Estructura_metal blanco
Paneles_melamina blanco
Porta_archivadores_metal blanco

Отделка_меламин орех
Структура_металл белый
Перегородки_меламин белый
Подставка для папок_меламин белый



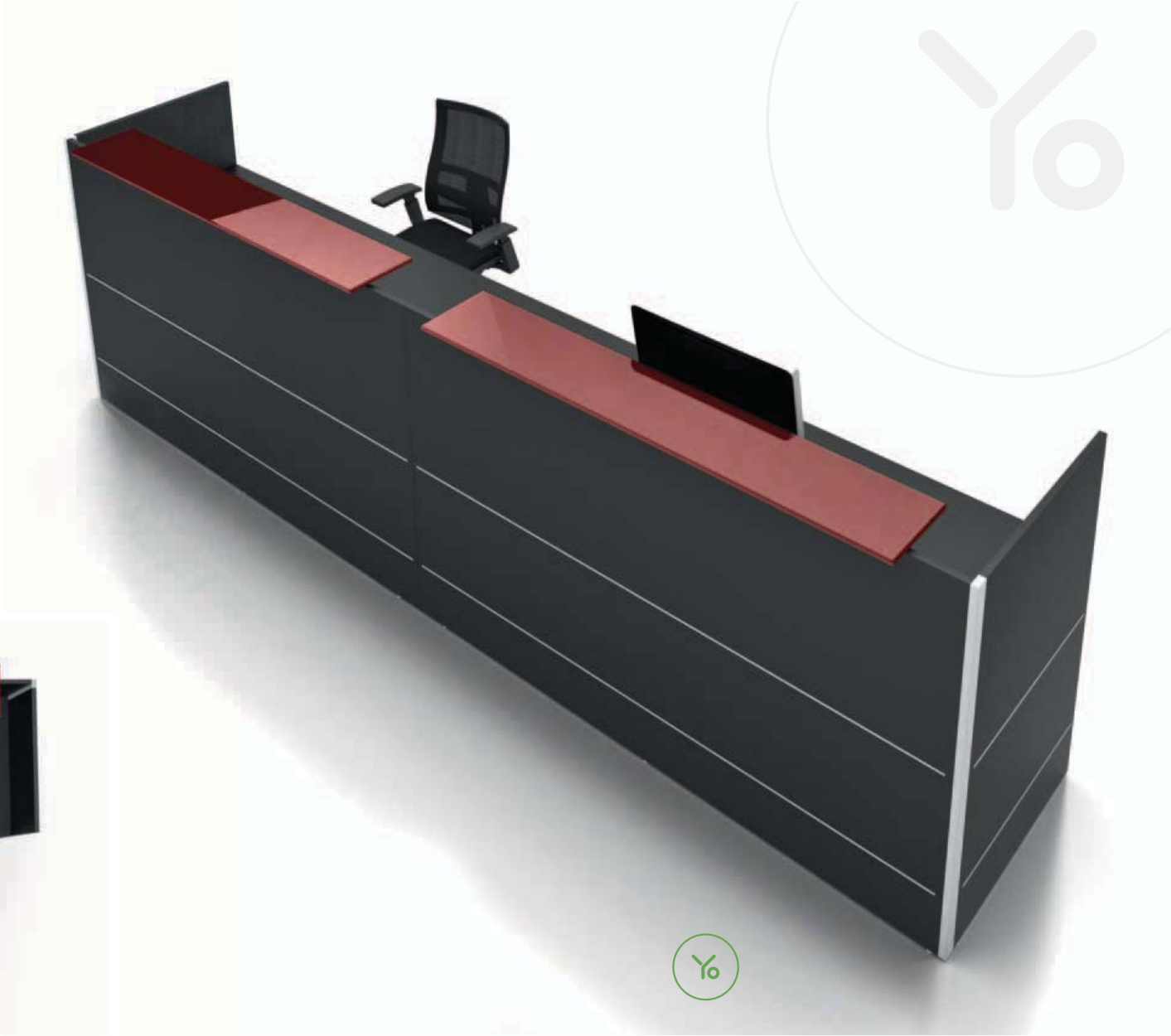

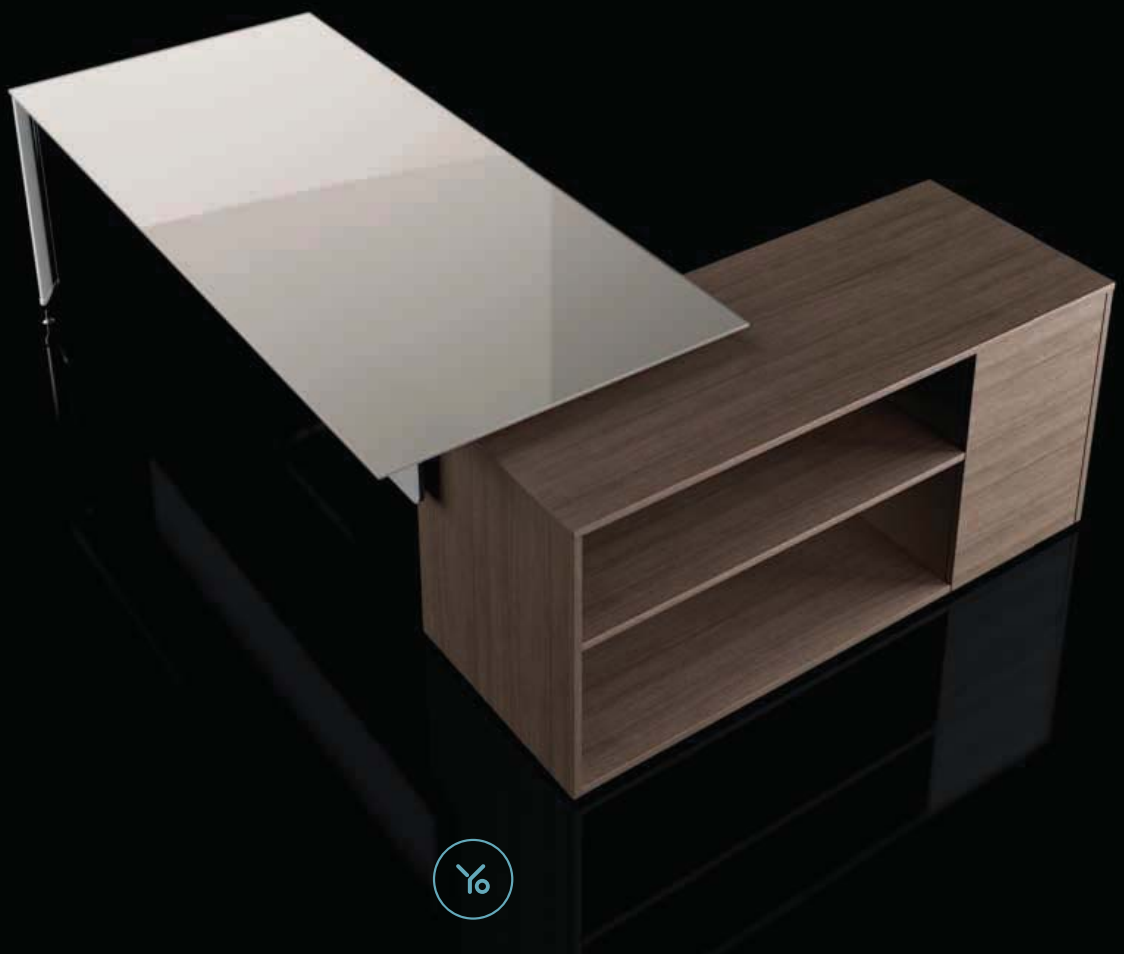



Finitura_cristallo antracite
Struttura_metallo cromato
Ante_cristallo Stopsoi

Finish_anthracite crystal
Structure_chromed metal
Doors_Stopsoi crystal

Finition_verre anthracite
Structure_métal chromé
Façades_verre Stopsoi

Oberfläche_Crystal Farbe anthrazit
Metallgestell_Farbe Metallic
verchromt
Türen_Crystal Stopsoi

Acabado_cristal antracita
Estructura_metal cromado
Puertas_cristal Stopsoi

Отделка_стекло антрацит
Структура_металл хромированный
Двери_стекло Stopsoi











FINITURE , FINISHES , FINITIONS , AUSFÜHRUNGEN , ACABADOS , ОТДЕЛКА

MELAMINICO , MELAMINE , MELAMINÉ , MELAMIN , MELAMINA , МЕЛАМИН

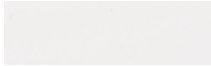

Blanco , White , Blanc , Weiß
Bianco , Белый



Antracite , Anthracite , Antracite , Anthrazit
Antracita , Антрацит



Grigio , Grey , Gris , Grau
Gris , Серый



Sabbia , Sand , Sable , Sand
Arena , Песочный



Noce , Walnut , Noyer , Nussbaum
Nogal , Дуб

CRISTALLO , CRYSTAL , VERRE , KRISTALLGLAS , CRISTAL , СТЕКЛО

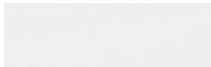

Blanco , White , Blanc , Weiß
Bianco , Белый



Antracite , Anthracite , Antracite , Anthrazit
Antracita , Антрацит



Rosso , Red , Rouge , Rot
Rouge , Красный



Corda , Tan , Corda , Corda
Cuerda , Cordá (last opened)

STRUTTURA SCRIVANIA , DESK STRUCTURES , STRUCTURES BUREAUX , TISCHGESTELLE , ESTRUCTURAS DE LOS ESCRITORIOS
СТРУКТУРЫ ПИСЬМЕННЫХ СТОЛОВ



Blanco , White , Blanc , Weiß
Bianco , Белый



Grafite , Graphite , Graphite , Graphit
Grafita , Антрацит



Cromo , Chrome , Chromé , Vanzhromit
Cromo , Хром

STRUTTURA ARMADI , STORAGE STRUCTURES , STRUCTURES ARMOIRE , SCHRÄNKE-STRUKTUREN , ESTRUCTURAS ARMARIOS
КОРПУСА ШКАФОВ



Argento , Silver grey , Argenté ,
Silber Plata , Серебряный



Antracite , Anthracite , Antracite , Anthrazit
Antracita , Антрацит

STRUTTURA ARMADI PORTANTI , SUPPORTING STORAGE UNITS STRUCTURES , STRUCTURES ARMOIRES PORTANTES , TRAGENDER
SCHRANK KORPUS , ESTRUCTURAS DE LOS ARMARIOS PORTANTES , СТРУКТУРЫ НЕСУЩИХ ШКАФОВ



Argento , Silver grey , Argenté ,
Silber Plata , Серебряный



Antracite , Anthracite , Antracite , Anthrazit
Antracita , Антрацит

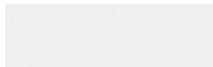

Blanco , White , Blanc , Weiß
Bianco , Белый

ANTE CRISTALLO , CRYSTAL DOORS , FAÇADES VERRE , TÜREN CRYSTAL , PUERTAS DE CRISTAL , СТЕКЛЯННЫЕ СТВОРКИ



Stopsol , Stopsol , Stopsol , Stopsol
Stopsol , Stopsol



Sabbieto , Sandblasted , Dépoli , Sand Ausführung
Esmerilado , Обработанный песком

SCREEN , SCREENS , CLOISONNETTE , TRENNWAND , PAREDES , ПЕРЕГОРОДКА

METACRILATO , METHACRYLATE , MÉTHACRYLATE , METHACRYLAT , METACRILATO , МЕТАКРИЛАТ



Fumé , Dark Grey , Fumé , Fumé
Ahumado , Дымчатый

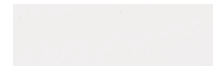

Blanco , White , Blanc , Weiß
Bianco , Белый

CRISTALLO , CRYSTAL , VERRE , KRISTALLGLAS , CRISTAL , СТЕКЛО



Sabbieto , Sandblasted , Dépoli , Sand Ausführung
Esmerilado , Обработанный песком



LED RGB , LED RGB , LED RGB , LED RGB
LED RGB , LED RGB

ACCESSORI , ACCESSORIES , ACCESSOIRES , ZUBEHÖRE , ACCESORIOS , АКСЕССУАРЫ

PORTADOX / PORTA SCREEN LATERALE , BINDER / LATERAL SCREEN HOLDER , RANGE-CLASSEURS / SUPPORT CLOISONNETTE LATÉRALE ,
FACH FÜR ORDNER/SEITE TRENNWAND , PORTA ARCHIVADORES / PORTA PARED LATERAL , КОНТЕЙНЕР ДЛЯ ПАПКОК / ПОДСТАВКА ДЛЯ БОКОВОЙ ПЕРЕГОРОДКИ

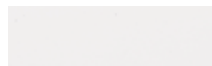

Blanco , White , Blanc , Weiß
Bianco , Белый













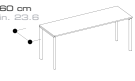
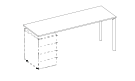

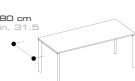
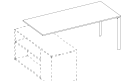

Antracite , Anthracite , Antracite , Anthrazit
Antracita , Антрацит

PASSAMANO CUIOIO | HIDE INLAY | SOUS-MAIN EN CUIR | LEDERAUFLAGE | VADE DE CUERO | КОЖАНЫЙ БЮВАР





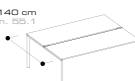
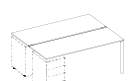
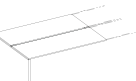
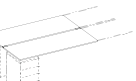

Nero , Black , Noir , Schwarz
Negro , Черный



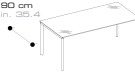

SCRIVANIE MELAMINICO , MELAMINE DESKS , BUREAUX MÉLAMINÉ , SCHREIBTISCHPLATTE MELAMIN , ESCRITORIOS DE MELAMINA
МЕЛАМИНОВЫЕ ПИСЬМЕННЫЕ СТОЛЫ

| | | | | | |
|---|--|--|--|--|--|
| cm 120 / 140 / 160 / 180 L 74 H in 47,2 / 55,1 / 63 / 70,9 W 29,1 H | | | | | |
|  60 cm in 23,6 |  AYD1810_M |  AYD1530_M |  AYD1520_M |  AYD1550_M | |
| cm 120 / 140 / 160 / 180 L 74 H in 47,2 / 55,1 / 63 / 70,9 W 29,1 H | | | | | |
|  60 cm in 31,5 |  AYD1590_M |  AYD1080_M |  AYD1540_M |  AYD1080_M | |
| cm 160 / 180 / 200 L 74 H in 63 / 70,9 / 78,7 W 29,1 H | | | | | |
|  90 cm in 35,4 |  AYD1600_M |  AYD1560_M |  AYD1570_M |  AYD1580_M | |
| cm 120 / 140 / 160 / 180 L 74 H in 47,2 / 55,1 / 63 / 70,9 W 29,1 H | | | | | |
|  140 cm in 35,4 |  AYD2010_M |  AYD2020_M |  AYD2030_M |  AYD2040_M | |

SCRIVANIE CRISTALLO , CRYSTAL DESKS , BUREAUX VERRE , KRISTALLSCHREIBTISCHPLATTE , ESCRITORIOS DE CRISTAL
СТЕКЛЯННЫЕ ПРИСТАВКИ

| | | | | | |
|--|--|--|--|--|--|
| cm 160 / 180 / 200 L 74 H in 63 / 70,9 / 78,7 W 29,1 H | | | | | |
|  90 cm in 35,4 |  AYD1600_C |  AYD1560_C |  AYD1570_C |  AYD1580_C | |

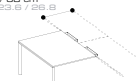
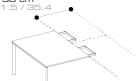
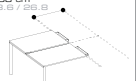
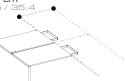

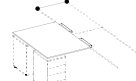
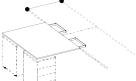
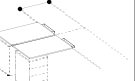
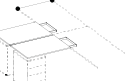



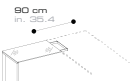
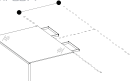
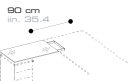
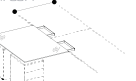

ALLUNGI MELAMINICO , MELAMINE EXTENSIONS , RETOURS MÉLAMINÉ , TISCHVERLÄNGERUNGEN MELAMIN
PROLONGACIONES DE MELAMINA , МЕЛАМИНОВЫЕ ПРИСТАВКИ

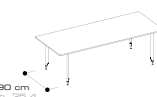
| | | | | | |
|---|---|---|---|---|---|
| cm 100 / 120 L 60 P 74 H in 39,4 / 47,2 W 23,6 D 29,1 H | | cm 100 / 120 L 140 P 74 H in 39,4 / 47,2 W 55,1 D 29,1 H | | cm 120 L 140 P 74 H in 47,2 W 55,1 D 29,1 H | |
|  60 / 68 cm in 23,6 / 26,9 |  80 / 90 cm in 31,5 / 35,4 |  60 / 68 cm in 23,6 / 26,9 |  80 / 90 cm in 31,5 / 35,4 |  60 / 68 cm in 23,6 / 26,9 |  80 / 90 cm in 31,5 / 35,4 |
| cm 100 / 120 L 60 P 74 H in 39,4 / 47,2 W 23,6 D 29,1 H | | cm 120 L 140 P 74 H in 47,2 W 55,1 D 29,1 H | | cm 100 / 120 L 140 P 74 H in 39,4 / 47,2 W 55,1 D 29,1 H | |
|  60 / 68 cm in 23,6 / 26,9 |  80 / 90 cm in 31,5 / 35,4 |  60 / 68 cm in 23,6 / 26,9 |  80 / 90 cm in 31,5 / 35,4 |  60 / 68 cm in 23,6 / 26,9 |  80 / 90 cm in 31,5 / 35,4 |





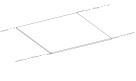

ALLUNGI CRISTALLO , CRYSTAL EXTENSIONS , RETOURS VERRE , TISCHVERLÄNGERUNGEN KRISTALL , PROLONGACIONES DE CRISTAL
СТЕКЛЯННЫЕ ПРИСТАВКИ

| | | | | | | | |
|---|---|---|---|--|--|--|--|
| cm 100 / 120 L 60 P 74 H in 39,4 / 47,2 W 23,6 D 29,1 H | | cm 100 L 140 P 74 H in 39,4 W 55,1 D 29,1 H | | cm 100 / 120 L 60 P 74 H in 39,4 / 47,2 W 23,6 D 29,1 H | | cm 100 L 140 P 74 H in 39,4 W 55,1 D 29,1 H | |
|  90 cm in 35,4 |  90 cm in 35,4 |  90 cm in 35,4 |  90 cm in 35,4 | | | | |





TAVOLI MELAMINICO , MELAMINE TABLES , TABLES MÉLAMINÉ , TISCHE MELAMIN , MESAS DE MELAMINA , МЕЛАМИНОВЫЕ СТОЛЫ

| | | | | | | | | |
|---|---|--|--|---|--|---|---|---|
| <p>cm 100 L 60 P 34 H in 39,4 W 23,6 D 13,4 H</p>  <p>AYD30202M</p> | <p>cm 220 L 110 P 74 H in 88,6 W 49,3 D 29,1 H</p>  <p>AYD30209M</p> | <p>cm 200/240/280 L 140 P 74 H in 78,7/94,3/110,2 W 55,1 D 29,1 H</p>  <p>AYD30262M</p> | <p>cm 80 L 90 P 74 H in 35,4 W 35,4 D 29,1 H</p>  <p>AYD30230M</p> | <p>cm 140 L 140 P 74 H in 55,1 W 55,1 D 29,1 H</p>  <p>AYD30256M</p> | <p>cm 140 L 140 P 74 H in 55,1 W 55,1 D 29,1 H</p>  <p>AYD302.M</p> | <p>cm 100 / 140 L 140 P 74 H in 39,4 / 55,1 W 55,1 D 29,1 H</p>  <p>AYD504.M</p> | <p>cm 140 L 140 P 74 H in 55,1 W 55,1 D 29,1 H</p>  <p>AYD50756M</p> | <p>cm 120/140/160/180 L 140 P 74 H in 47,2/63,1/78,7/93,9 W 55,1 D 29,1 H</p>  <p>AYD2040.M</p> |
|---|---|--|--|---|--|---|---|---|

TAVOLI CRISTALLO , CRYSTAL TABLES , TABLES VERRE , TISCHE KRISTALL , MESAS DE CRISTAL , СТЕКЛЯННЫЕ СТОЛЫ

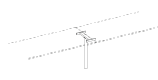
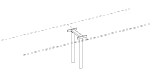
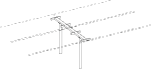
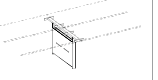
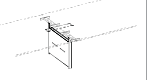
| | | | | | | |
|--|---|--|---|---|--|--|
| <p>cm 80 L 90 P 74 H in 35,4 W 35,4 D 29,1 H</p>  <p>AYD30230C</p> | <p>cm 140 L 140 P 74 H in 55,1 W 55,1 D 29,1 H</p>  <p>AYD30256C</p> | <p>cm 200/280 L 140 P 74 H in 78,7/110,2 W 55,1 D 29,1 H</p>  <p>AYD302.C</p> | <p>cm 100 / 140 L 140 P 74 H in 39,4 / 55,1 W 55,1 D 29,1 H</p>  <p>AYD504.C</p> | <p>cm 140 L 140 P 74 H in 55,1 W 55,1 D 29,1 H</p>  <p>AYD50756C</p> | <p>cm 160 / 180 L 140 P 74 H in 63/70,9 W 55,1 D 29,1 H</p>  <p>AYD2040.C</p> | <p>cm 80 L 90 P 74 H in 35,4 W 35,4 D 29,1 H</p>  <p>YD3720021</p> |
|--|---|--|---|---|--|--|

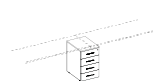
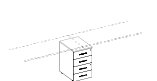
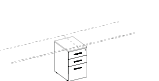
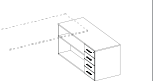
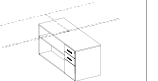

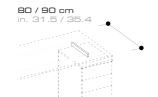
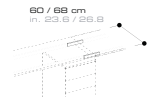
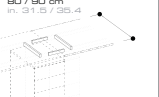
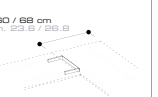
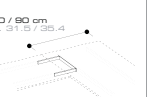

ELEMENTI DI SUPPORTO , SUPPORTING ELEMENTS , ÉLÉMENTS DE SUPPORT , STÜTZELEMENTE , ELEMENTOS DE SOPORTE
ОПОРНЫЕ ЭЛЕМЕНТЫ

| | | | | | |
|--|---|---|--|--|---|
| <p>cm 42 L 60 P 64 H in 16,3 W 23,6 D 25,2 H</p>  <p>AYD99004</p> | <p>cm 42 L 60 P 64 H in 16,3 W 23,6 D 25,2 H</p>  <p>AYD99005</p> | <p>cm 42 L 60 P 64 H in 16,3 W 23,6 D 25,2 H</p>  <p>AYD99006</p> | <p>cm 42 L 60 P 64 H in 16,3 W 23,6 D 25,2 H</p>  <p>AYD99007</p> | <p>cm 42 L 60 P 64 H in 16,3 W 23,6 D 25,2 H</p>  <p>AYD99011</p> | <p>cm 42 L 60 P 64 H in 16,3 W 23,6 D 25,2 H</p>  <p>AYD99011</p> |
| <p>cm 68 L 90 P 64 H in 27,5 W 23,6 D 25,2 H</p>  <p>AYD60035M</p> | <p>cm 68 L 90 P 64 H in 27,5 W 23,6 D 25,2 H</p>  <p>AYD60135M</p> | <p>cm 68 L 90 P 64 H in 27,5 W 23,6 D 25,2 H</p>  <p>AYD60043M</p> | <p>cm 148 L 58 P 64 H in 59,3 W 22,8 D 25,2 H</p>  <p>AYD63044M</p> | <p>cm 148 L 58 P 64 H in 59,3 W 22,8 D 25,2 H</p>  <p>AYD63045M</p> | <p>cm 148 L 58 P 64 H in 59,3 W 22,8 D 25,2 H</p>  <p>AYD63045M</p> |



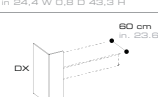
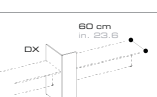

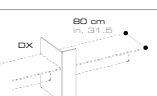



ELEMENTI STRUTTURALI , STRUCTURAL ELEMENTS , COMPLÉMENTS POUR STRUCTURES , ERGÄNZUNGSELEMENTE
ELEMENTOS ESTRUCTURALES , ДОПОЛНИТЕЛЬНЫЕ ЭЛЕМЕНТЫ СТРУКТУРЫ

| | | | | |
|---|---|--|---|---|
| <p>80 / 90 cm in 31,5 / 35,4</p>  <p>YD391503B</p> | <p>60 / 68 cm in 23,6 / 26,8</p>  <p>YD3909021</p> | <p>80 / 90 cm in 31,5 / 35,4</p>  <p>AYD99008</p> | <p>60 / 68 cm in 23,6 / 26,8</p>  <p>YD3902010</p> | <p>80 / 90 cm in 31,5 / 35,4</p>  <p>YD3903020</p> |
|---|---|--|---|---|

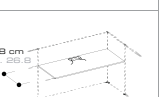
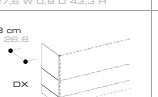

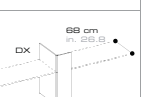
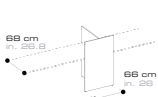
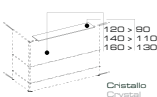

ELEMENTI DIVISORI , DESK PANELS , PANNEAU-PIED BUREAUX , TRENNWAND FÜR SCHREIBTISCH , PANELES PARA ESCRITORIOS
ОПОРНАЯ НОЖКА-ПАНЕЛЬ ПИСЬМЕННЫХ СТОЛОВ

| | | | | | |
|--|--|--|--|--|--|
| <p>cm 62 L 2 P 110 H in 24,4 W D,9 D 43,3 H</p>  <p>AYD40801M (DX) AYD40802M (SX)</p> | <p>cm 62 L 2 P 110 H in 24,4 W D,9 D 43,3 H</p>  <p>AYD40894M (DX) AYD40895M (SX)</p> | <p>cm 62 L 2 P 110 H in 24,4 W D,9 D 43,3 H</p>  <p>AYD40813M</p> | <p>cm 82 L 2 P 110 H in 32,3 W D,9 D 43,3 H</p>  <p>AYD40801M (DX) AYD40802M (SX)</p> | <p>cm 82 L 2 P 110 H in 32,3 W D,9 D 43,3 H</p>  <p>AYD40894M (DX) AYD40895M (SX)</p> | <p>cm 82 L 2 P 110 H in 32,3 W D,9 D 43,3 H</p>  <p>AYD40813M</p> |
|--|--|--|--|--|--|

RECEPTION , RECEPTION , BANQUES D'ACCUEIL , REZEPTIONSFLÄCHE , RECEPCIONES , СТОЙКИ РЕСЕПШЕН

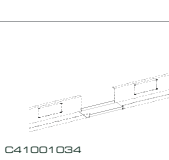
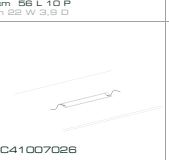
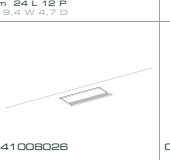
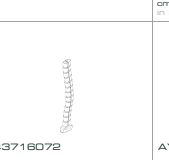
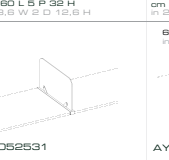
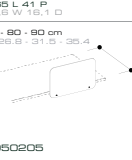
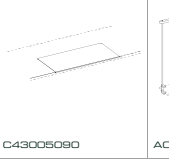
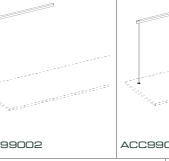
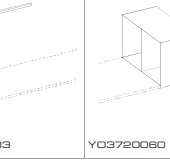
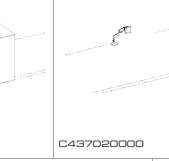
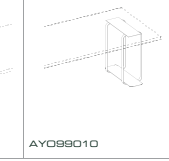
| | | | | | |
|---|--|---|--|--|--|
| <p>cm 120 / 140 / 160 L 2 P 110 H in 47,2 / 55,1 / 63 W D,9 D 43,3 H</p>  <p>AYD4080.M</p> | <p>cm 120 / 140 / 160 L 2 P 110 H in 47,2 / 55,1 / 63 W 26,8 D D,9 H</p>  <p>AYD4020.M</p> | <p>cm 120 / 140 / 160 L 2 P 110 H in 47,2 / 55,1 / 63 W 26,8 D D,9 H</p>  <p>AYD4100.M</p> | <p>cm 70 L 2 P 110 H in 27,8 W D,9 D 43,3 H</p>  <p>AYD40701 (DX) AYD40702 (SX)</p> | <p>cm 70 L 2 P 110 H in 27,8 W D,9 D 43,3 H</p>  <p>AYD40798 (DX) AYD40799 (SX)</p> | <p>cm 70 L 2 P 110 H in 27,8 W D,9 D 43,3 H</p>  <p>AYD40794 (DX) AYD40795 (SX)</p> |
| <p>cm 70 L 2 P 110 H in 27,8 W D,9 D 43,3 H</p>  <p>AYD40713M</p> | <p>cm 80 / 110 / 130 L 24,8 P 1,2 H in 35,4 / 43,3 / 51,2 W 9,8 D D,9 H</p>  <p>AYD5120.C</p> | <p>cm 80 / 110 / 130 L 24,8 P 1,2 H in 35,4 / 43,3 / 51,2 W 9,8 D D,9 H</p> <p>120 x 90 140 x 110 160 x 130</p> <p>Cristallo Crystal Verre Kristallglas Cristal Crème</p> | <p>cm 70 L 2 P 110 H in 27,8 W D,9 D 43,3 H</p>  <p>AYD40701 (DX) AYD40702 (SX)</p> | <p>cm 70 L 2 P 110 H in 27,8 W D,9 D 43,3 H</p>  <p>AYD40798 (DX) AYD40799 (SX)</p> | <p>cm 70 L 2 P 110 H in 27,8 W D,9 D 43,3 H</p>  <p>AYD40794 (DX) AYD40795 (SX)</p> |

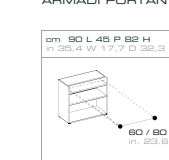
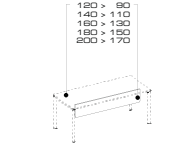
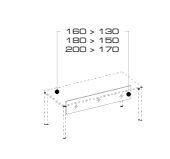
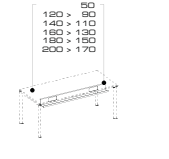
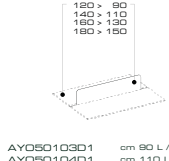
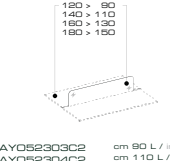
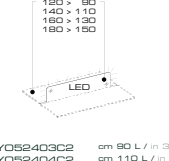



ACCESSORI , ACCESSORIES , ACCESSOIRES , ZUBEHÖRE , ACCESORIOS , АКЦЕССУАРИ

| | | | | | | |
|--|--|---|--|---|--|--|
|  C41001034 |  C41007026 |  C41008026 |  C43716072 |  AY052531 |  AY050205 | |
| cm 56 L 10 P in 22 W 3,9 D | | cm 24 L 12 P in 9,4 W 4,7 D | | cm 60 L 5 P 32 H in 23,6 W 2 D 12,6 H | | |
| cm 60 L 45 P 2 H in 35,4 W 17,7 D 32,3 H | | cm 60 L 31 P 37 H in 23,6 W 12,6 D 14,6 H | | cm 21,5 L 53,5 P 54 H in 8,5 W 21,1 D 21,3 H | | |
|  C43005090 |  ACC99002 |  ACC99003 |  Y03720060 |  C437020000 |  AY099010 |  MP3701054 |
| <p>120 > 90 140 > 110 160 > 130 180 > 150 200 > 170</p>  Y02501120M cm 90 L / in 35,4 W Y02501140M cm 110 L / in 43,3 W Y02501160M cm 130 L / in 51,2 W Y02501180M cm 150 L / in 59,1 W Y02501200M cm 170 L / in 66,9 W | | <p>160 > 130 180 > 150 200 > 170</p>  Y02503160C cm 130 L / in 51,2 W Y02503180C cm 150 L / in 59,1 W Y02503200C cm 170 L / in 66,9 W | | <p>50 120 > 90 140 > 110 160 > 130 180 > 150 200 > 170</p>  C41001050 cm 50 L / in 19,7 W C41001120 cm 90 L / in 35,4 W C41001140 cm 110 L / in 43,3 W C41001160 cm 130 L / in 51,2 W C41001180 cm 150 L / in 59,1 W C41001200 cm 170 L / in 66,9 W | | |
| <p>120 > 90 140 > 110 160 > 130 180 > 150</p>  AY0501030D1 cm 90 L / in 35,4 W AY0501040D1 cm 110 L / in 43,3 W AY0501050D1 cm 130 L / in 51,2 W AY0501060D1 cm 150 L / in 59,1 W | | <p>Metacrilato Methacrylate Methacrylate Methacrylat Metacrilato Metakrilat</p>  AY052303C2 cm 90 L / in 35,4 W AY052304C2 cm 110 L / in 43,3 W AY052305C2 cm 130 L / in 51,2 W AY052306C2 cm 150 L / in 59,1 W | | <p>Cristallo Crystal Verre Kristallglas Cristal Cristallo</p>  AY052403C2 cm 90 L / in 35,4 W AY052404C2 cm 110 L / in 43,3 W AY052405C2 cm 130 L / in 51,2 W AY052406C2 cm 150 L / in 59,1 W | | |
| <p>120 > 90 140 > 110 160 > 130 180 > 150</p>  AY052503C2 cm 90 L / in 35,4 W AY052504C2 cm 110 L / in 43,3 W AY052505C2 cm 130 L / in 51,2 W AY052506C2 cm 150 L / in 59,1 W | | <p>Cristallo con LED Crystal with LED Verre avec éclairage Led Kristallglas mit Led Cristal con LED Cristallo e iluminação Led</p>  AY052503C2 cm 90 L / in 35,4 W AY052504C2 cm 110 L / in 43,3 W AY052505C2 cm 130 L / in 51,2 W AY052506C2 cm 150 L / in 59,1 W | | | | |

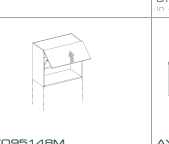

CASSETTIERE , PEDESTALS , CAISSONS , SCHUBLADENKÄSTEN , CAJONERAS , ТУМБОВИКИ

| | | | | |
|--|--|--|--|--|
|  AY060034M |  AY060042M |  C41108054 |  C41109054 |  C44206035 |
| cm 42 L 60 P 56 H in 16,5 W 23,6 D 22 H | | cm 42 L 54 P 53 H in 16,5 W 21,3 D 20,9 H | | |
| Melaminico Melamine Melamin Melamina Меламин | | Melaminico Melamine Melamin Melamina Меламин | | Metallo Metal Metal Metal Metall |
| Melaminico Melamine Melamin Melamina Меламин | | Metallo Metal Metal Metal Metall | Metallo Metal Metal Metal Metall | |

ARMADI PORTANTI , SUPPORTING STORAGE UNITS , ARMOIRES PORTANTES , STANDSCHRÄNKE , ARMARIOS PORTANTES , НЕСУЩИЕ ШКАФЫ

| | | | | | |
|---|---|---|--|--|--|
|  AY095148 |  AY095848 |  ACC96001 |  AY095148M |  AY02160_M |  AY02170_M |
| cm 90 L 45 P 62 H in 35,4 W 17,7 D 32,3 H | | cm 180 L 45 P 62 H in 70,9 W 17,7 D 32,3 H | | cm 90 L 45 P 62 H in 35,4 W 17,7 D 32,3 H | |
| cm 120 / 140 / 160 / 180 L 140 P 74 H in 47,6 / 55,1 / 63 / 70,9 W 55,1 D 29,1 H | | | | | |
| 60 / 80 cm in 23,6 / 31,5 | | 140 cm in 55,1 | | | |

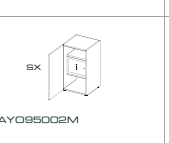
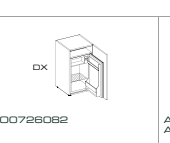
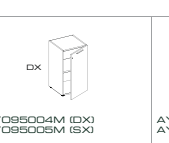
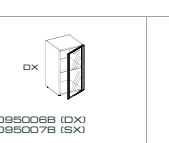
ARMADI H.82 , H.82 CM STORAGE UNITS , ARMOIRES H.82 CM , SCHRÄNKE H.82 CM , ARMARIOS H.82 CM , ШКАФЫ H.82 CM.

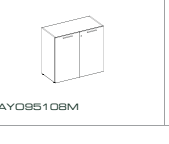
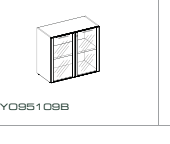
| | | | | |
|--|---|---|---|---|
|  ACC95001 |  AY095002M |  Y00726092 |  AY095004M (DX) AY095005M (SX) |  AY095006B (DX) AY095007B (SX) |
| cm 45 L 45 P 82 H in 17,7 W 17,7 D 32,3 H | | | | |
|  ACC95101 |  AY095108M |  AY095109B | | |
| cm 90 L 45 P 82 H in 35,4 W 17,7 D 32,3 H | | | | |

ARMADI H. 122 , H.122 CM STORAGE UNITS , ARMOIRES H.122 CM , SCHRÄNKE H.122 CM , ARMARIOS H.122 CM , ШКАФЫ H.122 CM.

| | | | | | |
|--|---|---|---|--|--|
|  ACC095201 |  AY095204M (DX) AY095205M (SX) |  AY095206B (DX) AY095207B (SX) |  ACC95301 |  AY095308M |  AY095309B |
| cm 45 L 45 P 122 H in 17,7 W 17,7 D 48 H | | | cm 90 L 45 P 122 H in 35,4 W 17,7 D 48 H | | |

ARMADI H.162 | H.162 CM STORAGE UNITS | ARMOIRES H.162 CM | SCHRÄNKE H.162 CM | ARMARIOS H.162 CM | ШКАФЫ H.162 CM.

| | | | | | |
|---|----------------------------------|----------------------------------|------------------------------------|----------------------------------|--|
| cm 45 L 45 P 162 H in 17,7 W 17,7 D 63,9 H | | | | | |
| | | | | | |
| ACC95401 | AY09541CM (DX) AY095411M (SX) | AY095404M (DX) AY095403M (SX) | AY095414MB (DX) AY095415MB (SX) | AY095406B (DX) AY095407B (SX) | |
| cm 90 L 45 P 162 H in 35,4 W 17,7 D 63,9 H | | | | | |
| | | | | | |
| ACC95501 | AY095508M | AY095503M | AY095516MB | AY095509B | |

ARMADI H.202 | H.202 CM STORAGE UNITS | ARMOIRES H.202 CM | SCHRÄNKE H.202 CM | ARMARIOS H.202 CM | ШКАФЫ H.202 CM.

| | | | | | |
|---|----------------------------------|------------------------------------|----------------------------------|------------|-----------|
| cm 45 L 45 P 202 H in 17,7 W 17,7 D 79,9 H | | | | | |
| | | | | | |
| ACC95601 | AY09561CM (DX) AY095611M (SX) | AY095614MB (DX) AY095615MB (SX) | AY095612B (DX) AY095613B (SX) | | |
| cm 90 L 45 P 202 H in 35,4 W 17,7 D 79,9 H | | | | | |
| | | | | | |
| ACC95701 | AY095722M | AY095706M | AY095703M | AY095716MB | AY095723B |

ARMADI SOPRALZO | BOOKCASES TO FIT ON STORAGE UNITS | ARMOIRES SUPERPOSABLES | SCHRANKAUFSÄTZE | ARMARIOS ALZADA | ШКАФЫ-НАДСТРОЙКИ

| | | | | | |
|--|----------------------------------|----------------------------------|---|------------------------|------------------------|
| cm 45 L 45 P 82 H in 17,7 W 17,7 D 32,3 H | | | cm 90 L 45 P 122 H in 35,4 W 17,7 D 48 H | | |
| | | | | | |
| ACC95901 | AY095904M (DX) AY095903M (SX) | AY095909B (DX) AY095907B (SX) | ACC96101 | AY096104M AY096103M | AY096106B AY096107B |
| cm 90 L 45 P 82 H in 35,4 W 17,7 D 32,3 H | | | cm 90 L 45 P 122 H in 35,4 W 17,7 D 48 H | | |
| | | | | | |
| ACC96001 | AY096008M | AY096009B | ACC96201 | AY096206M | AY096209B |

COMPLEMENTI ARMADI | STORAGE UNITS ACCESSORIES | COMPLÉMENTS POUR ARMOIRES | ZUBEHÖR FÜR SCHRÄNKE | ACCESORIOS PARA ARMARIOS | ДОПОЛНЕНИЯ ДЛЯ ШКАФОВ

| | | | | |
|---|---|---|---|---|
| cm 45 P 2 H in 17,7 D 0,9 H | cm 28 L 45 P in 10,9 W 17,7 D | cm 4 L 48 P in 1,8 W 19,1 D | cm 90 L 2 P in 35,4 W 0,9 D | cm 45 L 2 P in 17,7 W 0,9 D |
| | | | | |
| MP1212045M cm 45 L / in 17,7 W MP1212090M cm 60 L / in 23,4 W MP1212135M cm 136 L / in 53,1 W MP1212180M cm 160 L / in 70,9 W MP1212225M cm 225 L / in 89,9 W MP1212270M cm 270 L / in 106,3 W | MPO733090M cm 66 H / in 33,9 H MPO733160M cm 124 H / in 49,9 H MPO733160M cm 168 H / in 65,4 H MPO733206M cm 208 H / in 81,9 H | MP1512082M cm 84 H / in 33,1 H MP1512122M cm 124 H / in 49,9 H MP1512162M cm 164 H / in 64,9 H MP1512202M cm 204 H / in 80,3 H | MP2722082M cm 84 H / in 33,1 H MP2722122M cm 128 H / in 49,9 H MP2722162M cm 168 H / in 65,9 H MP2722202M cm 208 H / in 81,1 H | MP2721082M cm 84 H / in 33,1 H MP2721122M cm 128 H / in 49,9 H MP2721162M cm 168 H / in 65,9 H MP2721202M cm 208 H / in 81,1 H |
| | | | | |
| C43963000 | C43715086 | C43962086 | | |

Per una corretta costruzione delle composizioni, fare riferimento alle note tecniche del listino in vigore. For a correct set-up of the compositions, please see the technical notes on the price list. Pour construire correctement les compositions, veuillez vous référer aux notes techniques du tarif actuellement en vigueur. Für eine korrekte Aufbau der Kompositionen, die technische Hinweise der aktuellen u. gültigen Preisliste ansehen. Para componer correctamente las composiciones, véase las notas técnicas de la lista de precios en vigor. Для правильного составления композиций следует руководствоваться техническими замечаниями к актуальной прайс-листе.